

U-Scan Genesis™

Self-checkout systems



FUJITSU

U-Scan Genesis™ Self-Checkout

Advanced performance



From the world's leading provider of self-checkout solutions comes the most compact, intuitive and advanced U-Scan product line. The new U-Scan Genesis™ from Fujitsu is completely re-engineered to meet your customers' needs for simple, fast and efficient transactions while providing maximum flexibility, space-savings and reliability. The unique design of the U-Scan Genesis makes it highly adaptable to your store's own requirements—today and tomorrow.

Scalable by Design

Because your retail business is ever-changing, U-Scan Genesis has been designed to provide a modular and flexible architecture that makes it simple — and cost effective — for you to take advantage of future feature upgrades and make changes to your store's layout. U-Scan Genesis protects your self-checkout investment unlike any other solution on the market today.

Bagging stations — Varying capacities, including one-, two- and four-bag configurations, are available to accommodate your store volumes.

Cash dispensers — U-Scan Genesis offers a choice of either highly reliable coin canister dispensers or the high capacity hoppers.

Scanning technology — To complement your front-end equipment, U-Scan Genesis comes standard with a choice of Metrologic scanner/scales or can be outfitted with most other popular scanner/scales.

Rapid software integration — U-Scan's VPOS messaging framework architecture minimizes impact to your POS upgrade schedule, keeping your vital business software releases on-track.

The U-Scan Genesis is available in a multitude of languages, with the ability to switch languages mid-transaction—a powerful option in diverse markets when the attendant and customer speak different languages.



Customer-Driven Improvements

The U-Scan Genesis incorporates significant design improvements that make self-checkout simpler, more intuitive and faster for shoppers. All cash and coin accepting and dispensing is located together above the scanner, which speeds up the transaction process and reduces the likelihood of customers leaving money behind. The bill acceptor features accuracy and acceptance rates up to two times faster than other solutions on the market, while the completely redesigned bill dispenser significantly reduces bill jams—the most common service and maintenance issue.

All the primary components (customer display, scanner, receipt printer, coin and cash acceptors and dispensers, pin pad) are located within inches of each other, eliminating customer steps to and from devices located out of reach. A new “rich content” customer user interface and ATM-style “follow me” LEDs guide the customer through the checkout process.

Easy to Service

With the U-Scan Genesis, service and maintenance issues need not tie up your self-checkout lanes for extended periods of time. Easy serviceability enables your store associates to solve most simple maintenance issues quickly, so you minimize customer disruptions and greatly reduce service costs.

Replacing the receipt paper is as simple as opening a drawer; no key or supervisor is required. The CPU, coin hopper and bill dispensers are mounted on slide-out rails and shelves, with front accessibility that makes servicing or replacement of parts a snap, without tools, or complicated teardowns.

Reliable Performance

The U-Scan Genesis leverages many of the same advanced and reliable components as Fujitsu's other leading retail-hardened systems, to stand up to the demands of high volume checkout environments. With its “Direct Mode” feature, the U-Scan Genesis provides exactly the same functionality as your existing POS software application. This means there's no duplicative training for your cashiers; what they see at the POS is identical to what's visible in Direct Mode at the U-Scan Genesis.

The U-Scan Genesis also comes with an uninterruptible power supply (UPS), providing safe and clean stand-by power. In case of electrical service disruptions, you won't be plagued with lost transactions, voids and frustrated customers. Optional lane lights, assist shelves, bumpers and custom finishes are available so that you may customize your U-Scan Genesis installation for a unique and differentiating customer experience.

Fits Your Space

Featuring a smaller footprint than all previous U-Scan models, the U-Scan Genesis adapts to even tighter spaces and more locations, giving you the option to install more self-checkout lanes in the same square footage. With several models to choose from, retailers large and small alike can find a unit that will suit their needs.

U-Scan 1— Single-bag unit is perfect for small retail outlets, convenience stores, drug and discount retailers in both standard and express lane configurations

U-Scan 2— Dual-bag model works well in almost any retail store environment, where both bagging capacity and overall space savings are critical.

U-Scan 4— Four-bag system is perfect for higher volume supermarkets and mass merchandise retailers fitting in significantly less space than most popular 3-bag systems.

U-Scan Kiosk— Super-compact model with no bag scale is ideal for departments within larger stores or anywhere unassisted sales are needed.

U-Scan Payment Station— Full-service tendering only (coin and bill accepting and dispensing) model increases throughput during significant customer surges or where register space is limited.

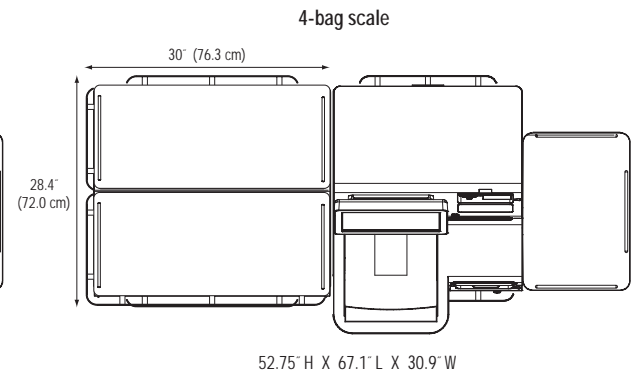
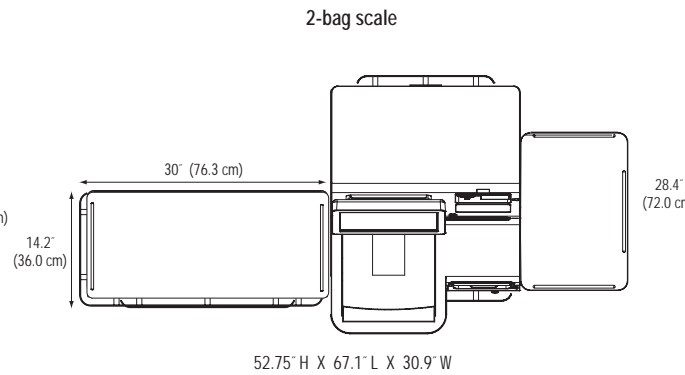
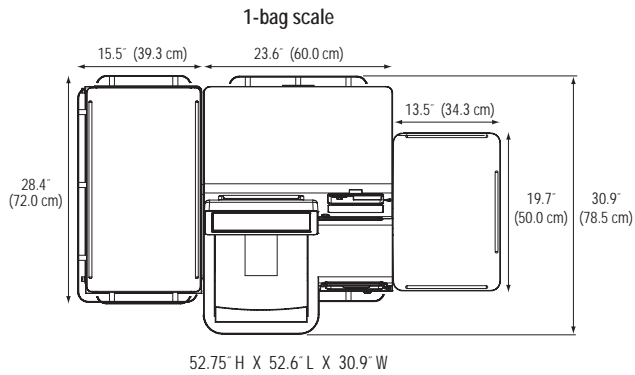

Because the U-Scan Genesis is modular, you can easily upgrade to a different capacity model and configuration as your self-checkout needs change.

You'll save even more space using the Fujitsu iPad mobile attendant, a wireless handheld device that performs the same functions as the fixed location attendant station. The iPad offers easy-to-use, fully-integrated software and allows cashiers to interact more freely with self-checkout customers and provide faster assistance.

Maximize Your ROI

Be sure to ask about our Self-Checkout Best Practices and U-Scan Training programs, designed to increase customer acceptance of your U-Scan system and maximize your return on investment. We provide real-world experience and expertise to our customers every day.

For more information on the U-Scan Genesis self-checkout systems contact Fujitsu today.

800-340-4425 • 858-457-9900 • us.fujitsu.com/retailing

U-Scan Genesis Specifications		
<p>System Software</p> <p>The U-Scan system can support the following POS applications:</p> <ul style="list-style-type: none"> ■ Fujitsu (GlobalSTORE and ISS400) ■ StoreNext (ISS45 V7, V8) ■ IBM 4680/90 (ACE, SA, GSA and CDSA) ■ Retailix StoreLine ■ POS 6300 ■ POS Plus (Retail for Windows) ■ NCR (Unity, ScanMaster) ■ UNIX ACR ■ UNIX Innovax/Aurora ■ Radiant 	<ul style="list-style-type: none"> ■ Choice in coin dispensers — hopper or canister style ■ Retailer's choice in Credit and Debit card readers ■ Proven Fujitsu bill dispensing technology ■ Non bar code item editor allows layout and content customization for items such as produce ■ Alphabetic search for non bar coded items ■ Proximity Sensor for auto activation ■ POS style receipt printer ■ Intuitive LED indicator lights that lead the customer to the right device at the right time ■ Proven Metrologic Scanner / Scales with optional conversion to NCR or PSC 	<p>Media and Tendering Options</p> <ul style="list-style-type: none"> ■ Cash (bills and coins) ■ Credit ■ Debit ■ Cash back ■ EBT ■ Checks ■ Coupons ■ WIC ■ Gift certificates, gift cards, store value cards ■ Coupon processing with automated verification
<p>"Scan and Bag" Terminals</p> <ul style="list-style-type: none"> ■ Retail-hardened cash dispensers, acceptors and PC units ■ Intuitive color touch screen interface with voice prompts ■ Multiple language support ■ Direct Mode to POS system ■ Portable, mobile device to manage entire U-scan operation 	<p>Options</p> <ul style="list-style-type: none"> ■ Digital over-scanner and cabinet entry cameras ■ Lane lights with status indicators ■ Electronic security key ■ Coupon insertion detector ■ Biometrics reader ■ Signature Capture pad 	<p>Security</p> <ul style="list-style-type: none"> ■ Artificial intelligence-based security algorithm ■ Weight scale under bag rack detects unscanned items ■ Video camera and attendant surveillance ■ EAS compatible (optional)
		<p>Technical Support</p> <ul style="list-style-type: none"> ■ 24 hours a day, 7 days a week